

# SP400 Rod /combined Instruction manual

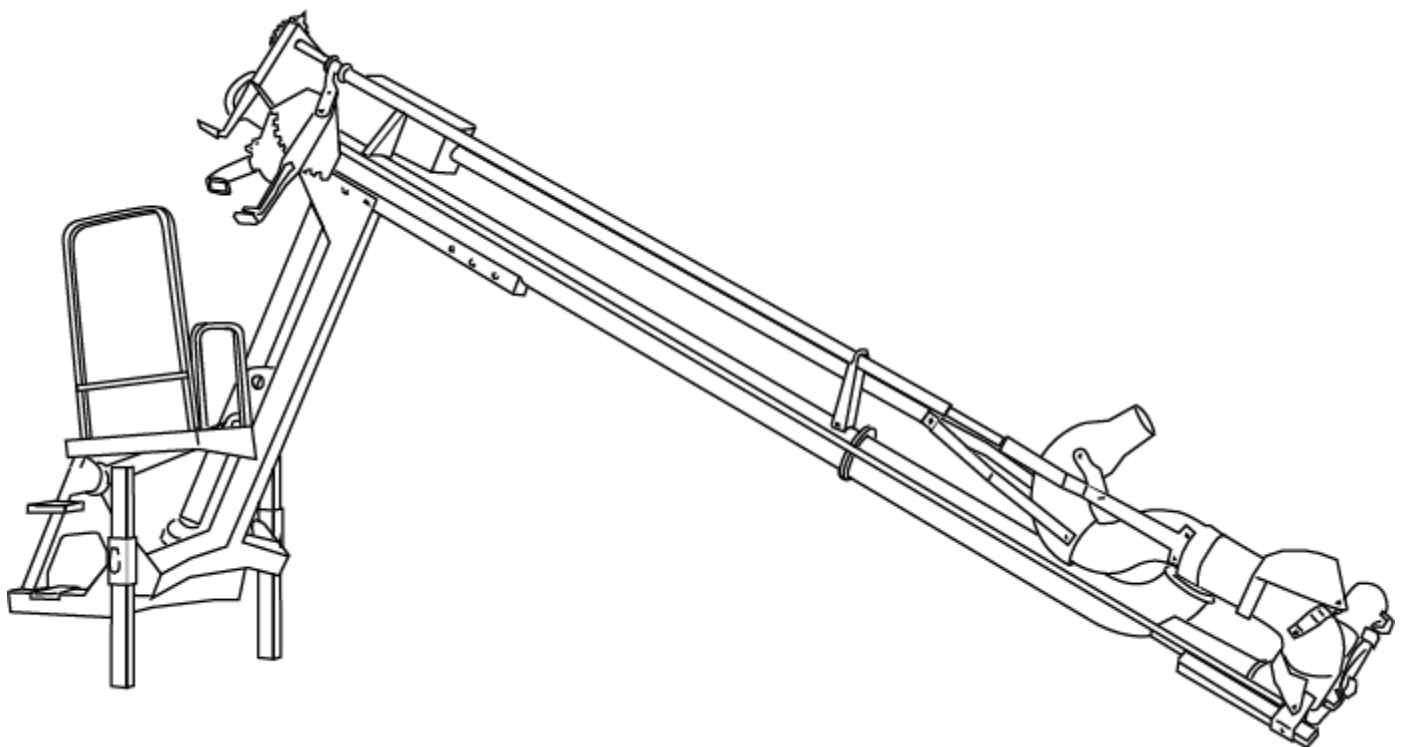

Congratulations on your Duun SP400 slurry pump.

All Duun tractor operated machines have been engineered and tested in close cooperation with representative users to produce functionally safe and user-friendly machines.

Please read this instruction manual before using the machine.

Good luck!

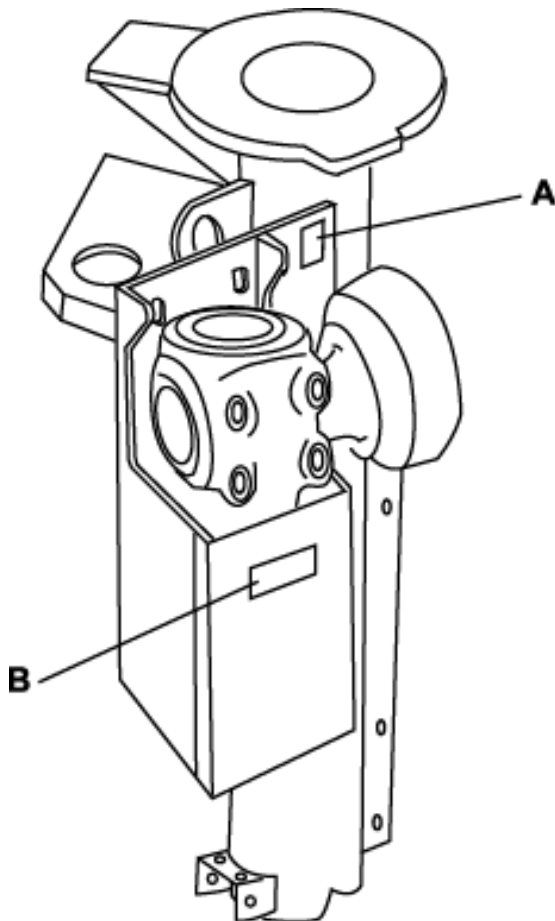

## Machine identification

Serial number and manufacturer are indicated on badge (A)

Register serial number and delivery time as indicated.

Always specify serial number when requesting service for the machine.

The machine is CE-marked (B). This marking confirms that the machine has been manufactured in conformity with EU Directive Machinery.

---

Serial number

---

Time of delivery (month/year)

# CONTENT

MACHINE IDENTIFICATION	2
SAFETY	4
WARRANTY TERMS	9
TECHNICAL DATA	10
ASSEMBLY INSTRUCTION	11
INSTALLATION OF MIRROR ATTACHMENT FOR ROD PUMP	12
PLATFORM INSTALLATION	13
USE IN DOOR OPENING	13
RISK OF THE MAIN CYLINDER OVERLOADING	15
LOWERING IN CONTAINER	15
WORK HEIGHTS	16
POWER TRANSMISSION SHAFT CONNECTION	16
LOADING SYSTEM INSTALLATION	16
MOUNTING INSTRUCTIONS, LOADING SYSTEM 8"	16
STIRRING	19
IMPELLER ADJUSTMENT	20
IMPELLER STORAGE MAINTENANCE/REPLACEMENT	20
GEARBOX	21
POWER TRANSMISSION SHAFTS	21
SERVICE AND MAINTENANCE	22
TROUBLESHOOTING FORM	24
GAS DANGER	25
DECLARATION OF CONFORMITY	26

# Safety

All operators, mechanics and the owner must always work carefully with agricultural machinery. Read and observe safety instructions in this instruction manual.



Be particularly aware of warning signs with this symbol, it marks measures that must be carried out in order to avoid accidents. The symbol appears in the instruction manual and on warning signs on the machine.

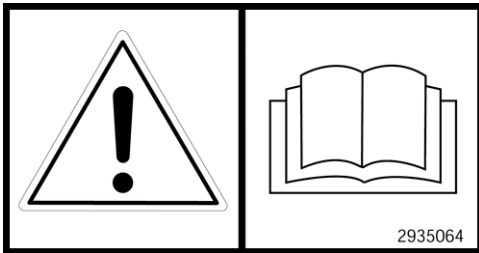

## Instruction manual

All operators, mechanics and the owner must be well acquainted with the instruction in this instruction manual before the machine is taken into use.

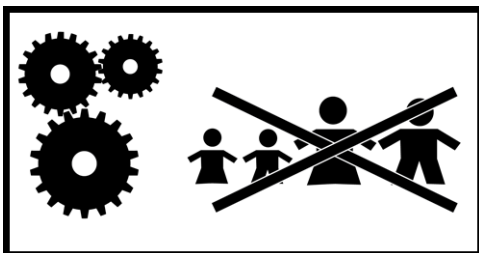

## Safety of the surroundings

Be very careful when other people or animals are near the machine or tractor. Never start the machine when there are people or animals close to it, also never stand between the tractor wheels and the machine!



## Be very careful during maneuvering and installing.

Ensure that no one is in the pump's operating radius or "impact area" during assembly and maneuvering.



## Avoid standing between pump and tractor.

During the use, any unnecessary standing between the pump itself and the tractor must be avoided.



### **Power transmission shaft**

The tractor is disengaged and the handbrake is applied before the shaft is connected to the tractor's PTO.

Max. PTO speed is 540 r.p.m. Make sure that there is the same angle in both joints (i.e. the pin on the tractor is parallel to the pin on the gearbox). Different angles cause imbalance, vibration and increased wear. The PTO shaft must always have the protective covers that were originally supplied. **Damaged and worn covers must be replaced immediately!**

**During raising and lowering of the pump rod, the power transmission shaft must be dismantled.**



### **Loading rack alternating load/ Variable load on the loading stand**

Ensure that the loading rack is anchored, loaded that it is stabilized during loading.

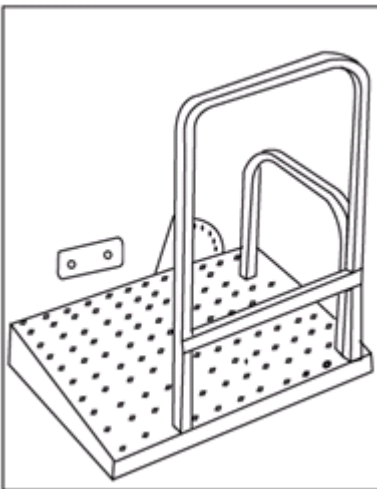

### **Work platform**

The work platform must always be mounted (applicable to combined and inclined pump) Standing on the work platform during the maneuvering is not permitted!

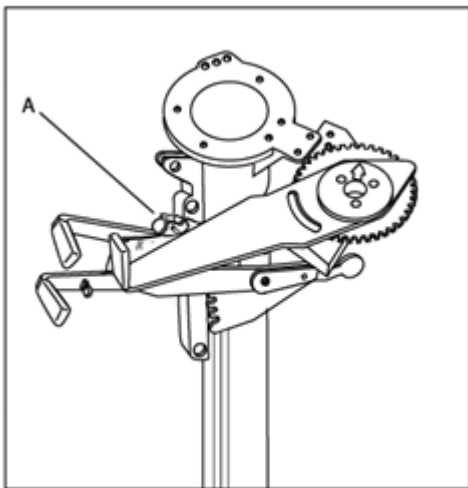

Be very careful when switching from stirring to loading. Avoid accidental loading by locking the outlet tap **(A)** of the loding tube during stirring.

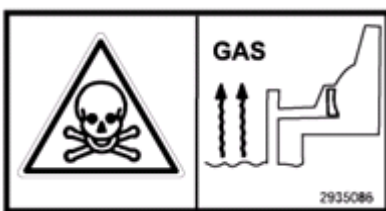

### Gas danger!

During stirring and loading of slurry, gas evolution occurs which in strong concentrations can be fatal for humans and animals. Follow the following safety regulations to avoid injury! - Avoid air flushing during stirring as far as possible!- Never go down into the slurry container without being completely sure that all the gas has been removed (can be checked with a gas meter that is submerged with a string) – Never work alone in a slurry container – at least two or even better three people, also use safety belts - a lifeline. – Use a fresh air mask! - open the door in the barn to minimize the amount of gas during slurry processing. Check the health in the farm building continuously during the pumping!- Avoid any unnecessary standing near the pump shaft and the pump during the work - stirring.



### Contact with current-carrying cables etc. during transport

Please note that the pump protrudes over the tractor during transportation and there is a risk of contact with live wires - railway underpasses and similar things!

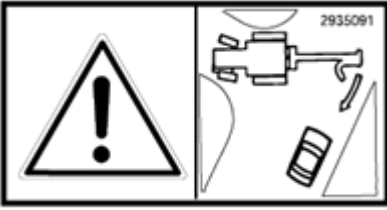

### Safe transportation

The pump has a very long turning radius behind the tractor. This can cause dangerous traffic situations when exiting and turning on a busy road. Be aware of this and avoid unexpected situations.

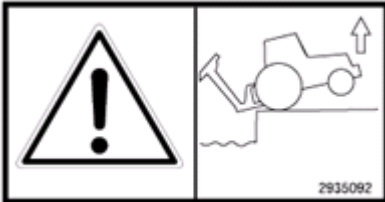

### Sudden danger during maneuver

The pump forms a long weight arm at the back of the tractor. This means that it can lift up the front of the tractor during removal from the warehouse. This is due to the fact that in such situations the pump has increased its weight with slurry mass in the pump housing and loading tube. The problem can be remedied with front weights or other load on the front of the tractor (loading device). Pay special attention to this and avoid fast maneuvers during removal from the slurry storage.

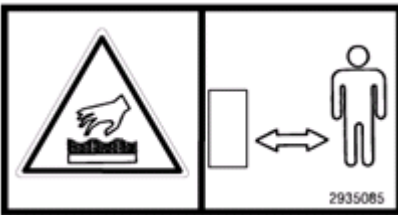

### Hot gearboxes

During heavy work, the working temperature in gearboxes reaches up to 90 degrees. (This partly depends on the ambient temperature). Therefore, avoid physical contact with the gearboxes during the use.



### Work noise

The noise level during use of the pump depends on the tractor's general noise level and the acoustics at the workplace. In certain cases this can exceed 85db. In such cases, the operator must use hearing protection.



### Hydraulics high fluid pressure

Be careful working with hydraulics. Use eye protection and gloves. Hydraulic oil under high pressure can penetrate the skin and cause serious infections. See a doctor if you have been injured. Ensure that no one is standing by when hydraulic functions are performed.



### **Rotating shaft**

Make sure that all covers for the shaft are in good condition and correctly fitted. Never start the machine without this being in order! Pay particular attention to the plastic covers on the power transmission shaft. If these are damaged, they must be replaced immediately! The locking chains for the plastic covers must always be attached to suitable fasteners on the pump to prevent the covers from rotating. The covers are lubricated according to the specified interval.

***If warning signs are removed during repairs or service, new signs must be installed immediately!***

### **Transportation**

#### **SP400 rod pump.**

If the pump is moved over long distances, it must be transported on a trailer.



## Warranty terms

Duun SP400 has 12 months guarantee against defects in materials and workmanship.

Parts that are not originally manufactured by Duun Industrier as, for example, wheels, hydraulic parts, etc. are subject to these suppliers' guarantees and terms.

In cases where a repair is considered to be covered by the guarantee, the representative must inform the supplier's representatives that the repair is intended executed based on the guarantee. In this context, the following information must be recorded:

- Product name
- The product's serial no. (see the machine identification)
- Date of sale
- The product owner's address, telephone no.

In case of such a repair, the supplier is presented with a claim within 3 weeks after the repair date.

Replaced parts are to be kept until a decision has been made with reference to the claim and the replaced parts are to be forwarded to Duun Industrier as for assessment if so required.

As the employment of the product is beyond our control, we may only guarantee the quality and do not accept liability for the product's general performance.

Duun Industrier as reserves the right to modify the design and specifications and/or make alterations and improvements without notification.

What is not included in the guarantee:

- The guarantee does not cover economic loss as a consequence of interruptions.
- The guarantee does not cover consequential loss due to defects.
- The guarantee does not cover defects or damage caused by misuse and uses that are not in accordance with the instruction manual's specifications and guidelines.

## Technical data

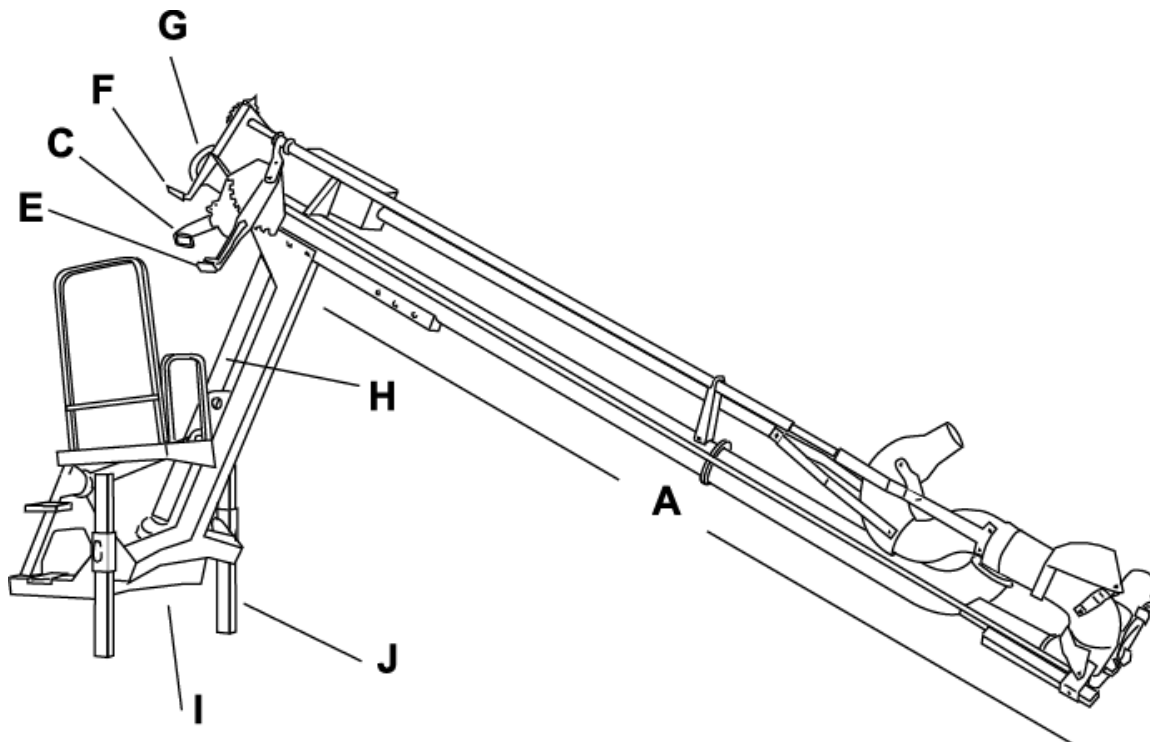

Weight:	
SP400 Rod	from 550 to 570 kg
SP400 Combi	from 920 to 960 kg
The total length of the pump A	4300mm
Walking distance of vertical nozzle	1120mm
Minimum vertical nozzle height	810mm
Nozzle diameters	150mm standard 115mm additional equipment (1312543)
Handle for outlet tap	C
Handle for nozzle height adjustment	E
Handle for swinging the nozzle	F
Bauer coupling	G
Hydraulic cylinder for raising/lowering	H – Only applies to combi pumps
Pump rack	I
Support leg	J
Turning sector nozzles	280 degrees
Power demand PTO	From 60 hp pto 540 r.p.m. for rod pumps and combi 1312501 From 85 hp pto 540 r.p.m for combi pump 1312503 and 1312505 (high performance)
PTO speed	540 r.p.m.
Gearbox replacement	1:2,42 for rod and combi pumps 1312501 1:2,15 for combi pumps 1312503 og 1312505 (high performance)
Impeller speed at 540 r.p.m	1328 r.p.m. for rod and combi pumps 1312501 1167 r.p.m for combi pumps 1312503 and 1312505 (high performance)
Gearbox oil	Statoil Mereta 150 – Esso Synthetic EP 150
<i>All measurements and weights are approximate values.</i>	

## Assembly instruction

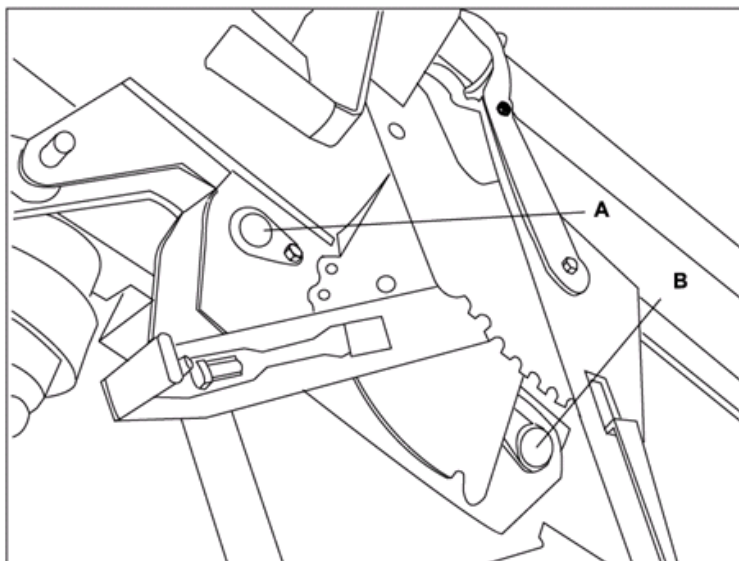

### Combination model

The pump is delivered packed on a EUR pallet with all relevant information. They are selected and the three-point linkage is connected to the tractor and the hydraulic cylinder is driven to fill it with oil.

The fixings for the support legs are screwed in place with a M16x45mm screw with washer and nut. The support legs are mounted and secured with a bolt and ring pin with a chain attachment.

The pump is lifted high enough to pass under the tractor attachments and the screw (A) with the locking screw installed.

The attachment to the pump takes place by lifting the tractor part that the channel on the pump part slides into the place in the tractor part. Bolt number 2 is mounted. (B)

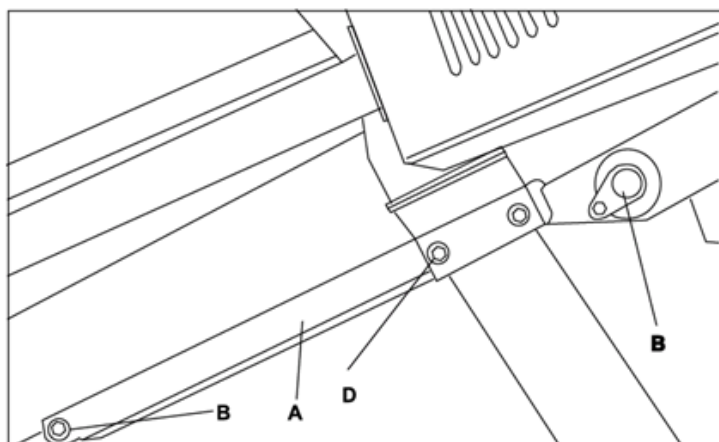

### Rod model

The pump is delivered packed on a EUR pallet with all relevant information. They are selected and connected to the tractor's front loader or to the tractor's three-point linkage. Telescopic struts (optional equipment) are then required. Forklift attachments designed for various standards like Trima SMS, Ålø + Euro. If the Euro coupling is used, it does not have the ability to attach directly to the rear of tractor's three-point. Euro connector can only be used for front loader operation!

The pump is lifted so high that the tractor attachment can be driven under and 2 pcs. M16x140 screws D attached.

Support arm and loader attachment are screwed together with 6 sk.M16x40 screws with washer and locking nut.

## Installation of mirror-facing attachment for rod pump

1. The pump is installed in the pump attachment with the circular pump tube facing the tractor and the slider is placed in the opposite direction.
2. The gearbox for the pump must have the PTO pin facing the tractor and must possibly be turned 180 degrees.
3. The main attachment itself is assembled with 6 screws M12x35 which are also attached to 2 pcs M16x150 (item 1 in the parts catalogue) in the slide on the pump stem. If it is desired that the pump should run freely up and down, these can be removed.
4. During fitting a mirrored pump, item 131279006, support leg (A) is required as illustrated. This should ensure that the pump rests on it when set aside. The leg (1) is attached to the mounting bracket (2) and the corresponding screws, 4 pcs M10x30. The leg must be permanently mounted and does not interfere with the operation of the pump.

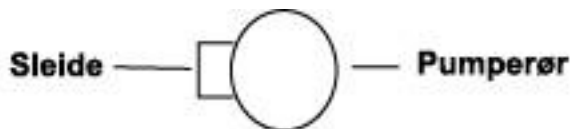

### Støttefot for hensetting

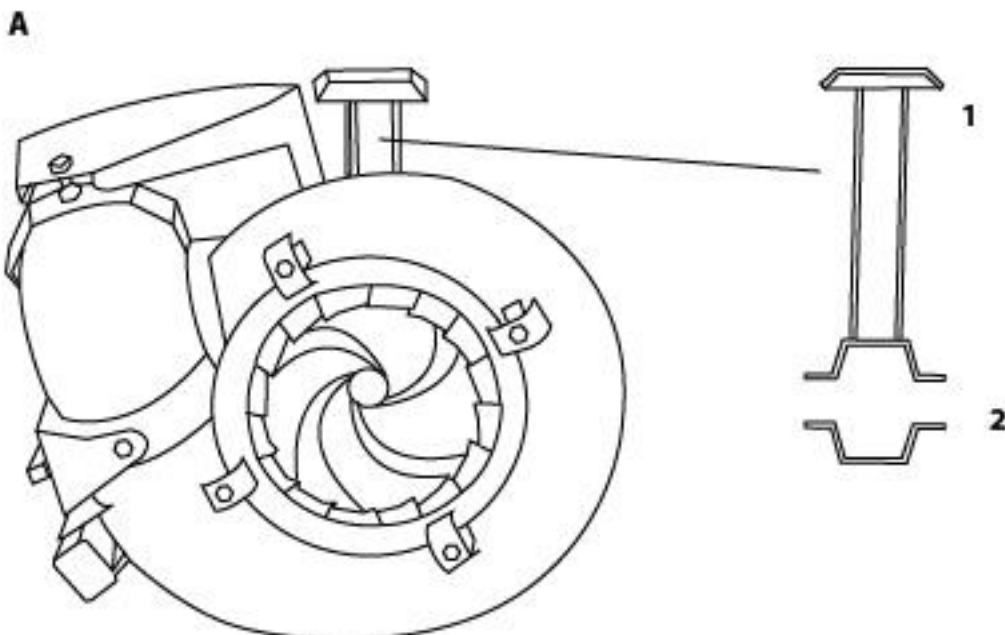

## Platform installation

The combination pump is always used with a firmly fixed working platform.

The railings **A** are attached with 4 pcs. 8x45 screws with a washer and a locking nut.

Transverse rods **B** 1 pc. assemble with screw 8x45 with washer and locking nut. The two railings are connected with angle **C**, which is mounted on the inside.

The platform itself is connected to the pump with 2 pcs. screws M16x45 in points **E**.  
Spacer plate **D** is mounted between platform and attachment.

When the pump is used for working in an inclined position, the platform is installed only at point **E** with 2 pcs. hexagon screws M16x45.

The angle of the platform is adjusted by selecting the mounting holes at points **F**.

When the pump is used for work in a vertical position, the platform is only mounted in points **E** and **G** with 2 pcs. hexagon screws M16x45. This also applies in cases where railings are mounted on a pure rod pump.

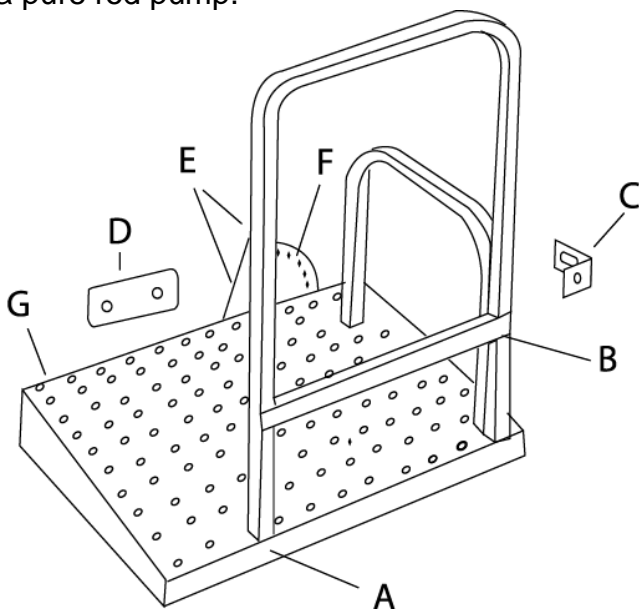

## Use in door opening

### SUPPORT LEG ADJUSTMENT

Before using the inclined pump, adjust the support leg to the retracted position as outlined **H**.

### REQUIREMENTS FOR OPENING HEIGHT WIDTH

Plug openings:

Wall/gate: H:90cm, B:110 cm.  
Min.75x90 cm.

Height above gate: 2,2m

Rod pump shaft: 80x80cm  
Min. 70x70cm

Shaft for combi pump: L:150 cm, B90cm  
Min. 125x90cm

Measure the thickness of the door 110 mm!

### EVEN SURFACE

It is a big advantage that the tractor has an even surface that the pump housing does not get unintentional movements which could damage the door during the pump's run-in.

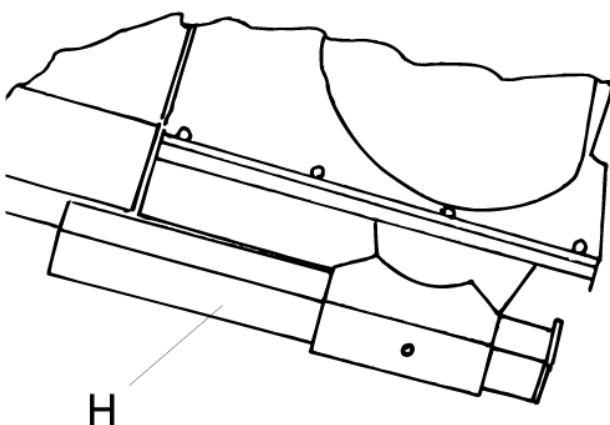

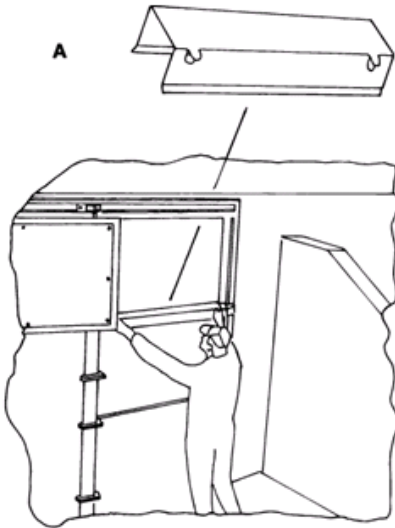

### PROTECTIVE COVER

Protective cover A (part no. 1311951) must be fitted before entering the door opening.  
Not standard equipment.

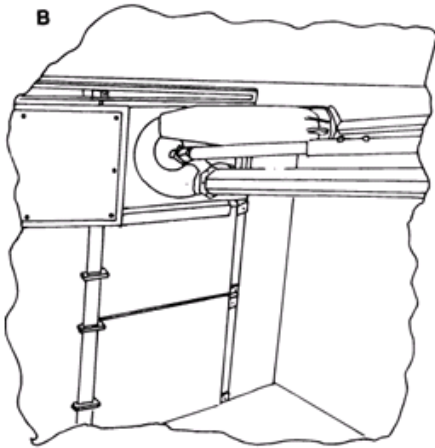

### SETTING FOR INSERTION

To take up as little space as possible during entry into the gate opening, the nozzle is turned as far as possible to the left. In addition, the nozzle should be positioned upwards as much as possible. **B**

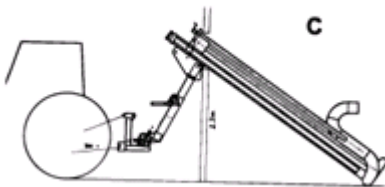

### WORKING HEIGHT SETTING

The pump can work above a door height of 220cm as outlined C.

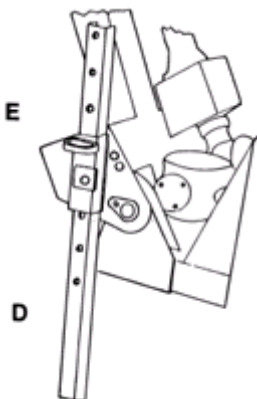

After driving in, set the support leg at the most vertical angle possible and at the correct height **D** with the adjustment bolt **E**.

### CORRECT SHAFT ANGLE

To avoid unnecessary vibrations and wear on the power transmission shaft and gearbox, make sure that the shaft pin from the gearbox is parallel to the tractor's PTO shaft.

## Risk of the main cylinder overloading

### Applies to combination pump.

During insertion and use, follow these guidelines: Let the main cylinder make movements with strong resistance.

**NB! Please note that a hydraulic top strut can transfer loads to the main cylinder which, in the worst case can break the piston rod.**

## Lowering in container

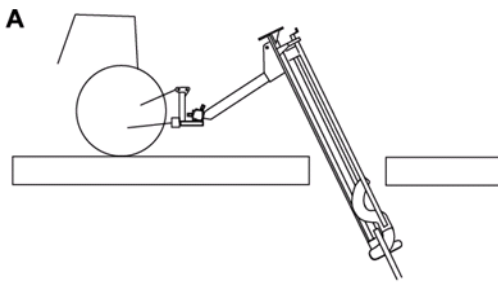

Before submerging the pump in shaft opening **A**, ensure that the outlet nozzle points straight forwards or backwards in the tractor's longitudinal direction. In order for the nozzle to take up as little space as possible during lowering, it is set in a position that it points upwards as much as possible.

In the case of submerging in a shaft as outlined, the opening length is approx. 120 cm and width 80 cm with a 30 cm thick cover.

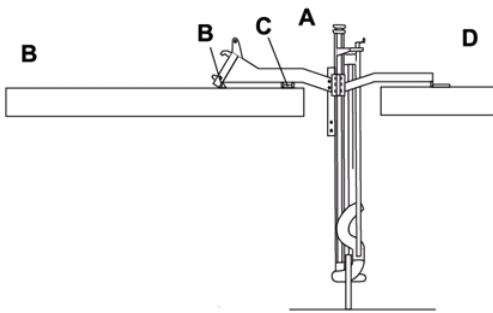

### Rod pump lowered into sump/container. (B)

SP200 rod pump is mounted in a container using the SMS (Trima) front loader. The support leg is pulled out and the pump is lowered into the bottom. In order for the pump to be permanently mounted, the tractor attachment must be lowered to the concrete surface by removing the 2 screws **(A)**. During the pump mounting again, at least one of the screws must be fitted. The pump is anchored with suitable screws in the fasteners **B, C** and **D**. Our recommended size is 16mm or larger.

If the pump is used over an edge and the attachment **D** cannot be used, it is very important the pump is on the support leg and the attachment at points **B** and **C** takes place before the pump is released from the tractor. Otherwise, the pump can disappear in the slurry storage.

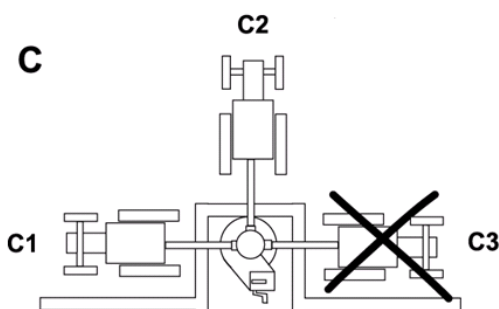

### Blind angle in shaft mirrored rod pump attachment

Duun SP200 combi pump can work efficiently when placed in working positions C1 and C2. In position C3, a combi pump will only cover half of the required sector for stirring.

Duun SP400 rod pump standard version can work efficiently when placed in working positions C1 and C2. In position C3, a standard rod pump will only cover half of the required sector for stirring.

### Mirrored rod pump

To be able to work effectively as a rod pump in position C3, the rod pump is supplied with a mirrored attachment.

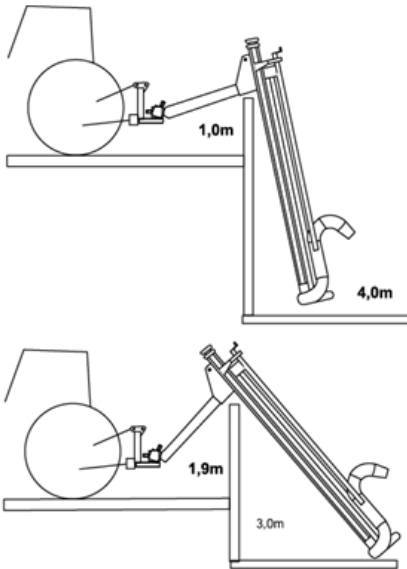

## Work heights

The pump can work efficiently in basins up to 4.2m deep with differences in height as specified.

## Power transmission shaft connection

Connect the power transmission shaft between the pump and the tractor. The speed of the shaft is limited to 540 rpm max. Always have the same angle in both joints (i.e. the pin on tractor parallel to the pin on gearbox). Different angles cause imbalance and more wear/attrition.



## Loading system installation

The Bauer coupling is supplied with a 60' bend as standard on combi and inclined pumps.

(article.no.1312020) See parts catalogue p.66-67

45' (article.no. 1312021) is supplied as an additional equipment.  
90' (article.no. 1312022) is supplied as an additional equipment.

SP200 rod pump is supplied with 2x45' PP plastic bends at each end.

The loading system is delivered fully assembled. During expanding, use normal 160mm PP tube which can be obtained from a local plumber.

Support legs 2 pcs. The 30x30 square pipe is mounted in a pre-mounted bracket and adjusted in height with **D** 2 pcs. M8x25 hexagon screws with counter nut.

The rack should be weighted before driving to ensure stable loading.

**ATTENTION! All screws in the loading system must be checked and possibly retightened at regular intervals.**

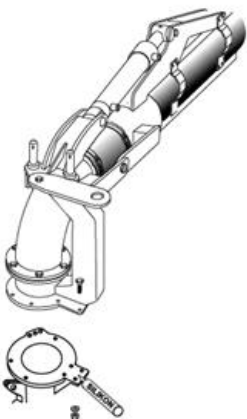

## Mounting instructions, loading system 8''

The loading system is supplied partly fully assembled. During the connection with a pump unit, the loading system is lifted up with a crane or front loader. The two mounting surfaces are cleaned and inserted with silicone. The included screws are used for assembly.

Hydraulics are connected and oil is poured. Test the system thoroughly before releasing the suspension. The extension of the loading system uses standard 200mm PP tubes which can be purchased from your local plumber.



## Hydraulics Layout for loads and loading/stirring



See the next page for an explanation of the pictures.

**Hydraulic operation of loading-stirring + operation of loading tubes, a total of 3 functions.**

Positions 1 and 2 are marked 2958129 and 2958130 and must be connected to the cylinder for raising/lowering the loading tube.

Positions 3 and 4 are marked 2958127 and 2958128 and must be connected to the cylinder for lateral movement of the loading tube.

Positions 5 and 6 are marked 2958131 and 2958132 and must be connected to the cylinder for regulation between loading and stirring.

The hose marked A is the pressure side from the tractor.

The hose marked B is the return side of the tractor. The return hose has a non-return valve that prevents pressure from building up on the return hose.

An anti-seize valve is standard from 2014 and can be retrofitted on older pumps if the loading tube leaks.

Non-return valve is standard from 2016 and can be retrofitted on older pumps.

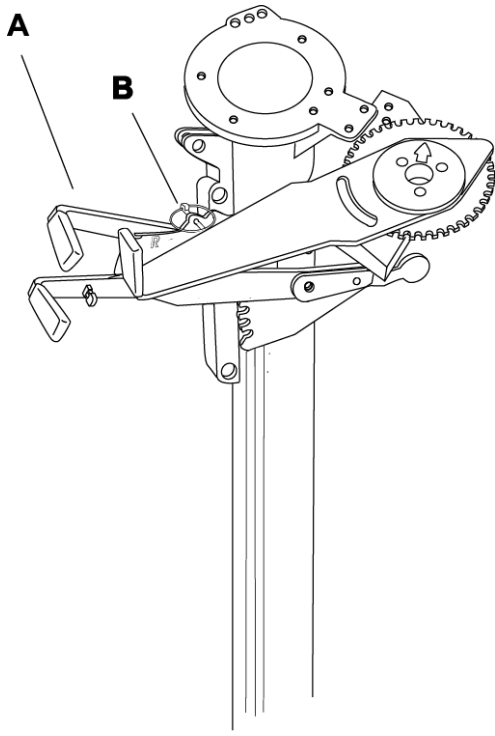

## Stirring

1. Stirring causes a gas danger - take safety measures and checks!
2. Close the outlet opening to the loading tube by placing the loading handle **A** in position **R** and locking it in this position with ring pin **B**.
3. Start by directing the outlet jet towards the floating layer on the surface around the pump. Turn the nozzle sideways and upwards so that the fluid layer around the pump becomes moistened and thin.
4. If the slurry turns out to be too dry (syrupy consistency) water must be added. The addition of water results in thinner slurry and a far more efficient stirring. Do not start loading the slurry until the entire content is well mixed.
5. Once the surface slurry has been stirred and homogeneous, the jet is directed towards the bottom of the container so that the bottom layer is also well stirred before discharge.
6. Due to the fact that large quantities of slurry is delivered through the outlet nozzle, raising and lowering the nozzle and turning to the side requires reducing the speed of the tractor. Then the operation will be much easier.
7. It is easier to change the stirring side at the same time as loading, because then slurry does not flow through the nozzle.
8. If stirring is carried out without constant supervision, the loading handle for the loading tube should be locked with padlock **B** to prevent accidental loading.

## ALTERNATIVE OUTLET NOZZLES

Outlet nozzle **E** can be supplied in various diameters to regulate the flushing pressure from the pump.

### LOADING

1. Check that the loading tube is correctly assembled and properly anchored. Pay attention to the anchoring/loading to keep the outlet in place!
2. Start loading by moving the handle **A** for this (left side) to position **L**. This is done gradually to prevent impact loads !!
3. After the tank wagon is full, the loading is finished by moving the handle over **R** for stirring.
4. Avoid dry running of the plastic bearing below the impeller. This is lubricated by the slurry mass and will be damaged when driving above the liquid level.

**NB!** The pump can pump thicker slurry than some tankers are able to spread. It may be an advantage not to fill the wagon on the first load and possibly add water if necessary.

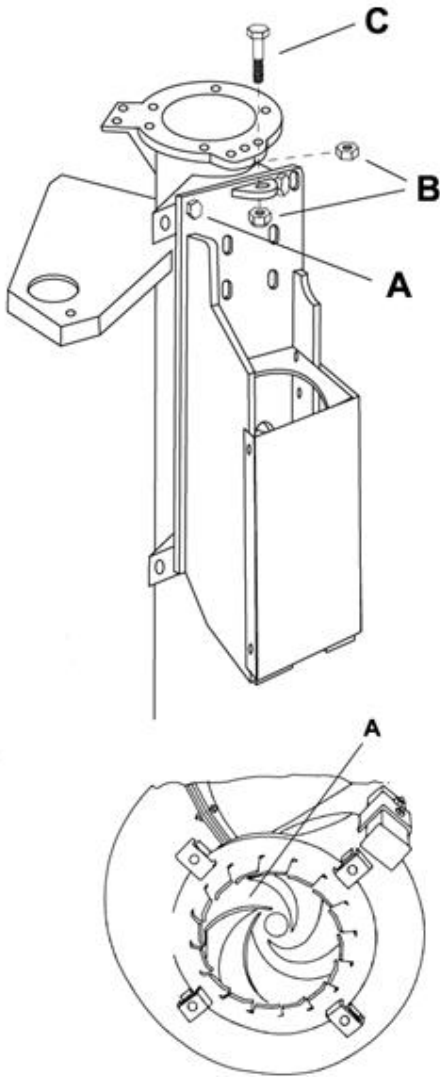

## Impeller adjustment

To maintain good cutting capacity, the distance between the impeller and the inlet ring must be 2-3mm (**A**). The distance is checked at least once per season or after 40 hours. If the distance is too small, a bump may occur which causes vibrations. Too large a distance will result in a loss of power.

The distance is adjusted as follows:

1. Loosen the screws holding the gearbox **A**.
2. Loosen the set screws **B** and adjust with the screws **C** to the recommended distance **A** 2-3 mm between the inlet ring and the impeller.
3. The set screws **B** are tightened.
4. Tighten the screws holding the gearbox **A**.

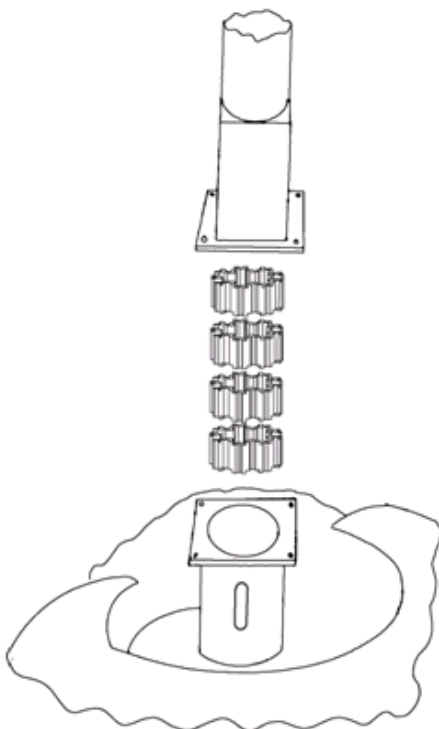

## Impeller storage maintenance/replacement

The lower part of the pump shaft near the impeller is stored in a plastic bearing.

The bearing is lubricated by the slurry mass and therefore does not need separate lubrication.

Ensure that the bearing operates below the slurry level during the use to avoid wear.

The wear of the bearing should be checked at least once per season or after 40 operating hours.

If the gap between the pump shaft and the bearing is 1.5mm or more, it should be replaced.

This is done in the following way:

1. Loosen the four fastening screws for the cover tube.
2. Loosen the two screws connecting the cover tubes.
3. Lift the cover tube.
4. Remove the old bearing and press in the 4 new parts after the bearing housing and grooves have been lubricated with grease.
5. Lower the cover tube and fasten the screws.

## Gearbox

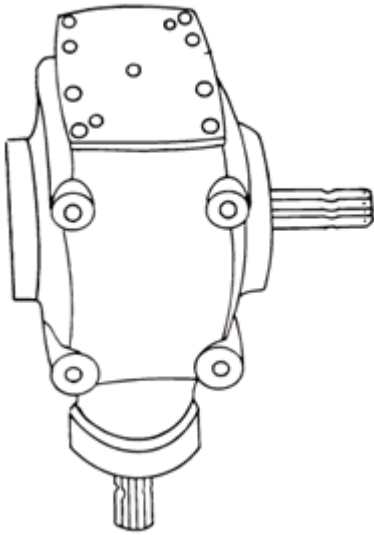

Recommended oil: Gearbox oil Mereta 150/220 synthetic oil (Statoil) or Esso Synthetic EP150.  
Other oil must maintain the standard SAE90EP or GL5  
Synthetic oil must always be used Mereta 150/220 - Per liter - article no. 531 0 110

The first oil change is recommended after 40 hours of use. Check the oil level after 40 operating hours or after each season. On the single gearbox, the oil level should be 150mm below the top of the flat cover with the correct quantity and vertical gearbox. For the double gearbox, the level is checked by loosening the center screw in a horizontal position as outlined (oil should then leak out at a sufficient level).

Oil changes are carried out every second season if the gearbox is stored outdoors uncovered in a humid climate with large temperature variations. If the gearbox is stored at a temperature or covered well, the oil should be changed every three seasons.

If 150 operating hours occur before the above, the oil should be changed with Mereta 150 as prescribed.

The oil content in the gearboxes depends on the manufacturer.

The simple gearbox contains:

Comer T-22A	2,3 litres
GB 02227	2,8 litres
BYPY	2,5 litres

The double gearbox contains:

Comer T-276D	2,2 + 2,2 litres
GB 02229	2,0 + 2,0 litres
BYPY	1,35 + 1,35 litres

**It is an advantage to change the oil when the gearbox is warm.**

**It is very important to fill the gearbox with the correct amount of oil.**

**Too much oil will lead to a higher operating temperature and risk of breakdown.**

**The oil level is checked by loosening the center screw when the gearbox is in a horizontal position.**

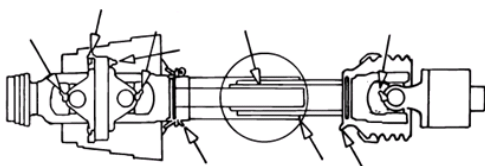

## Power transmission shaft

Lubricate the power transmission shafts at indicated points before use and every 8 hours.

\* During operating below freezing, the protective tubes are lubricated to prevent freezing.

The shaft is cleaned and lubricated before it is put away for a long period of time.

# SMØRINGS- OG VEDLIKEHOLDSSKJEMA

A. Kraftoverføringsaksel

B. Gearkasser

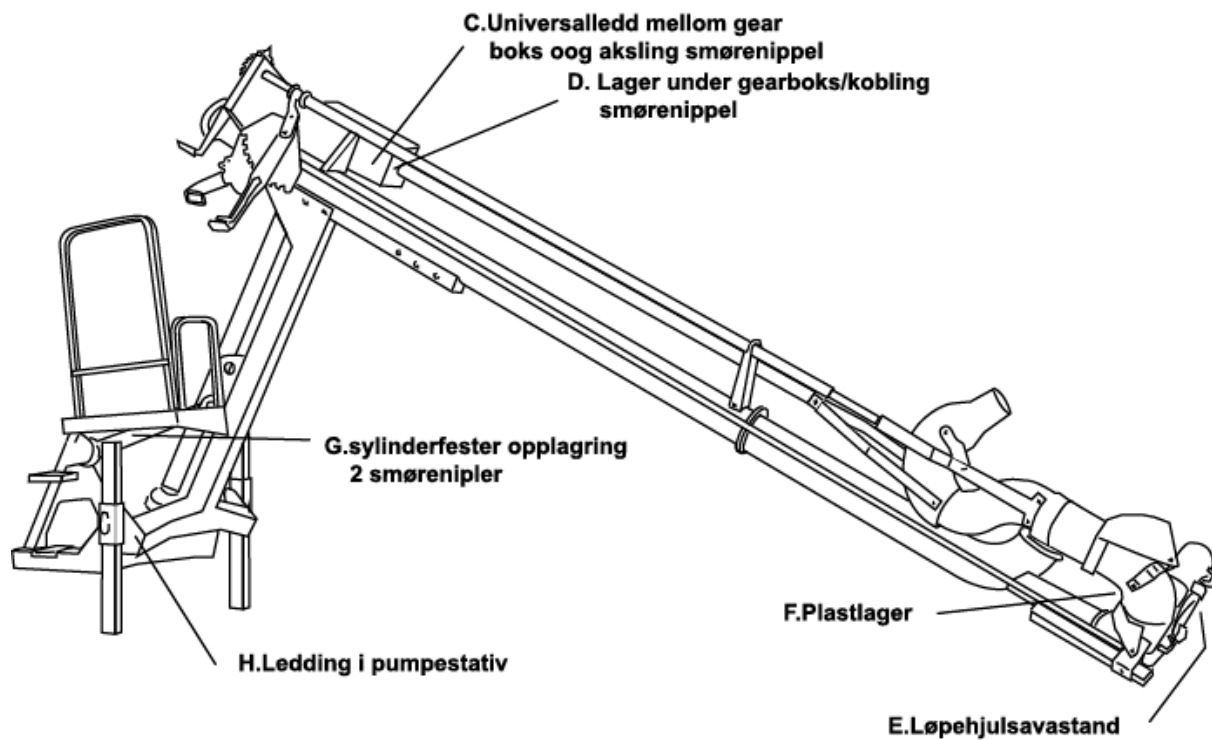

## Lubrication and maintenance

	Daily or every 8 hours	Every other day or every 20 hours	Every season or every 40 hours
<b>A.</b> Power transmission shaft. see. p.21	X	X	
<b>B.</b> Gearbox See p.21			X
<b>C.</b> Universal joint - lubrication nipple	X		X
<b>D.</b> Lager under garkasse/kobling lubrication nipple			X
<b>E.</b> Distance of impeller Check according to page 20			X
<b>F.</b> Plastic bearing Check according to			X
<b>G.</b> Cylinder attachments Lubrication nipple (2pcs.)	X		
<b>H.</b> Joint in pump - x stand.	X		

**Retighten all screws and nuts after 5-10 hours of use.  
Bolts and moving parts are lubricated as needed.**

## Troubleshooting form

Problem	Cause	Solution
Low capacity	Pumping air around the pump housing.	Add water and flush down the area around the pump. Do not throw away the soft mass to block the pump with a dry mass. Raise the pump with the hydraulic cylinder during operation. If installed.
	Thick slurry.	Add water. The pump can handle a maximum of 9-10% dry matter.
	Deformed impeller.	Change the pump impeller, also check the inlet ring and pump shaft.
	Incorrect distance in the pump housing. The pump housing Too close to the floor. Worn out cutter.	Adjust the distance between the impeller and inlet ring according to the instructions.  Extend the support leg. Change the cutter and adjust the distance.
Vibrations	Excessive deviation in the angle of driver's joints. Power transmission shaft are not parallel to taps from tractor and gearbox.	Max 20' on drive joint. Raise the tractor or lower the pump - Raise or lower the front of the tractor.
	Bent shaft.	Replace the shaft and all cover tubes. Check the universal joint in the coupling.
	Worn out plastic bearing.  Driving at critical speed.	Check and, if necessary, change the bearing for the impeller. Certain revs can cause vibrations. Avoid this by a small increase/decrease in speed.
The Pump stops	Safety slint in power shaft is broken.	Change the safety cotter pin in the shaft between tractor and gearbox. (screw M10x60 8.8 qual.)
	The safety pin in the claw coupling is broken.	Replace safety pin. Ref. Spare parts cat.
	The safety pin at the impeller is broken.	Replace safety pin. Ref. Spare parts cat.
Bearing breakdown upper bearing	The bearing has been lubricated too much and the seals in the bearing have been pushed out. Foreign elements (round bale strings) are located between the impeller and the pump housing and pulls the drive shaft down and creates tension in the bearing.	
Manure sprays out from the top of the cover pipe	The three drainage holes at the bottom of the cover tube are blocked. Dried slurry mass or foreign elements may have lodged in the cover tube. Pick up the pump and flush the drainage holes. Detach the cover tube from the pump housing and flush the inside of the cover tube cleanly.	



## Gas danger

Measures and points in connection with slurry gas.

1. Extraction fan in the basement contributes to the negative pressure and draws out the gas.
2. If there is an open connection between the cellar and the animals housing , the grates can be covered with plastic to contribute a negative pressure when an extraction fan is used.
3. A gas-tight connection between the animal housing and the basement provides better security, especially when combined with an exhaust fan in the basement.
4. Stir under wind - if possible with open windows and doors and closed gate.
5. If the discharge from stirring flows into the surface of the slurry storage, strong gas evolution occurs - especially in the starting phase. This is due to mixing of air and slurry mass.
6. Open doors in the barn that the gas will have a low outlet in the farm building itself.
7. Use gas meter all the time in the animal rooms during slurry pumping. We believe this is absolutely necessary, regardless of the pump type and whether or not you have a tight connection.
8. Avoid unnecessary stay in the vicinity of the pump shaft and the pump during slurry application and stirring.

We therefore recommend the IBT article (Department of Technical Sciences ÅS/NLH) no. 33/87 "measures against slurry gas poisoning" for more details.

## Declaration of conformity

### Responsible person

Name: Karl Martin Eggen  
Position: CEO  
Company name: Duun Industrier as  
Address: N-7630 Åsen  
Norway  
Telephone: +47 74 01 59 00

Person responsible for the technical documentation: Rolf Even Duun

Declares that the following machine: SP400 Slurry pump  
Manufacturer: Duun Industrier as  
Type: Duun Slurry pump SP400  
is in accordance with:

Directive 2006/42/EC Machinery

Signed by:



Karl Martin Eggen

Åsen, 15.09.2020